



## Features:

- Voltage & Current Digital Meters
- Voltage & Resistance Programmable
- Aluminum Case
- 220VAC Voltage Input available
- Input Voltage: 115VAC or 240VAC
- Load Regulation: 0.01% NL - FL (typ)
- Line Regulation: 0.01% (Vin +/- 10%)



## HR Series Description and Application Notes:

The HR series power supplies are a proven high quality low cost resonant switching design. Both voltage and current are adjustable from front panel 10-turn potentiometers. The units can also be remotely programmed by voltage or resistance. Remote controls are via a 9 pin D connector located on the back of the unit. An external enable is offered for safety. All units offer SLO-start feature with ramp up time less than 3 seconds. The high voltage output is through a coax cable assembly located in the rear of the chassis. This chassis is not grounded and allows the output to be floated above the case by 50 VDC. All units feature arc protection.

The HR Series high voltage power supplies are regulated by virtue of a resonant -sine wave Pulse Width Modulation topology. Here, a pulse driver converts a duty-cycle modulated square wave into a sinusoidal waveform by means of a high-Q resonant tank circuit. By using a resonant circuit, the high efficiency pulse drive is now converted to an amplitude modulated waveform which is stepped up by a high frequency high voltage transformer. The output from the transformer is fed into a high voltage multiplier circuit which converts the AC into a high voltage DC output. The DC output is regulated by a high gain closed loop circuit which adjusts for both line and load variations to within 0.01%. Since the HR series is both voltage and current regulated, two independent control loops operate in an automatic cross-over method. The front panel knobs for voltage and current set the limiting values.

The HR series may be both voltage and resistance programmed. An internal reference voltage of 11.5 VDC is adjusted down and used as signal input to the non-inverting pin of an operational amplifier. The closed feedback loop senses the output voltage and feeds this signal back to the inverting pin of the operational amplifier. Both voltage and current are regulated in this manner. By adjusting the control with either a resistance to ground or an external voltage source, the feedback loop is adjusted which varies the regulated output. A voltage of 0 to 10 VDC placed on the voltage control line will vary the output voltage from 0 to 100%. Likewise, a voltage of 0 to 10 VDC placed on the current control line will vary the maximum output current from 0 to 100%. Resistance programming is achieved by placing a resistance between the control line and ground. A value of 1 kOhm will lower the output (voltage or current) to 50%. In this configuration, it is possible to short the control line to zero to lower the output to the minimum. If an control voltage of above 12 volts is placed on the control line from an external source, the voltage will Zener clamp.

The interlock / enable must be connected to ground prior to turning on the unit. If this line is not grounded, the output will remain at zero. In addition, since this unit is both voltage and current regulated, the front panel current control must set at a value higher than zero to achieve an output voltage.

## Product Selection Table

Model	Output Voltage	Output Current	Ripple
HR-1	0 to 1000VDC	0 to 100.00mA	<0.05%
HR-2	0 to 2000VDC	0 to 50.00mA	<0.05%
HR-5	0 to 5000VDC	0 to 20.00mA	<0.05%
HR-10	0 to 10,000VDC	0 to 10.00mA	<0.05%
HR-15	0 to 15,000VDC	0 to 6.67mA	<0.05%
HR-20	0 to 20,000VDC	0 to 5.00mA	<0.05%
HR-30	0 to 30,000VDC	0 to 3.33mA	<0.05%
HR-50	0 to 50,000VDC	0 to 2.00mA	<0.05%
HR-75	0 to 75,000VDC	0 to 1.33mA	<0.05%
HR-100	0 to 100,000VDC	0 to 1.00mA	<0.05%
HR-125	0 to 125,000VDC	0 to 0.80mA	<0.05%

## HR Series Outline Drawing

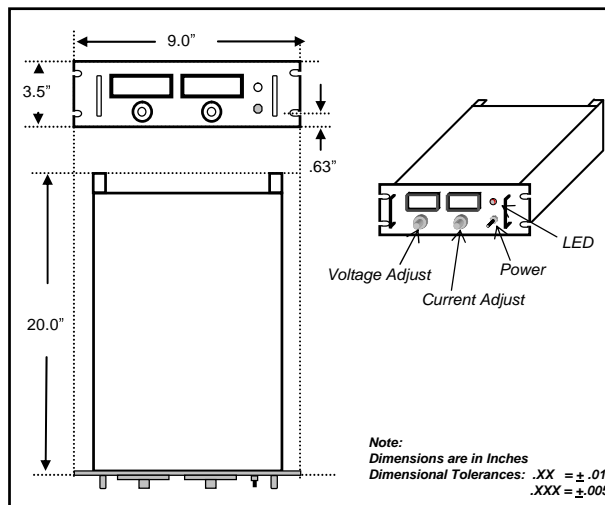

## Schematic Equivalent

